

Low Voltage General Purpose Motors

LV Open drip proof motor section



ABB

Making you more competitive

ABB's General purpose motor is designed for use in general industry, meeting the demands of standard applications for OEM's. Motors are readily available from central stock locations and distributors around the world. The motors have high build quality, are available with all the features needed by the OEM market and can be modified to meet most specifications.



ABB is a global leader in power and automation technologies that enable utility and industry customers to improve their performance while lowering environmental impact. The ABB Group of companies operates in around 100 countries and employs about 107,000 people.

Low Voltage General Purpose Motors

Sizes 56 to 400, from 0.055 to 630 kW

	Contents	Page	
1	General information	4	1
2	Aluminum motors	11	2
3	Steel motors	79	3
4	Cast iron motors	111	4
5	Open drip proof motors	145	5
6	Global motors	165	6
7	Brake motors	189	7
8	Single phase motors	215	8

ABB reserves the right to change the design, technical specification and dimensions without prior notice.

General information

Standards

ABB motors are of the totally enclosed and open drip proof, single or three phase squirrel cage type, built to comply with international IEC and EN standards. Motors conforming to other national and international specifications are also available on request.

All production units are certified to ISO 9001 international quality standard as well ISO 14000 environmental standard and confirm to all applicable EU Directives.

IEC / EN

Electrical	Mechanical
IEC/EN 60034-1	IEC 60072
IEC/EN 60034-2	IEC/EN 60034-5
IEC 60034-8	IEC/EN 60034-6
IEC 60034-12	IEC/EN 60034-7
	IEC/EN 60034-9
	IEC 60034-14



M000001



M000002



M000003



M000029

Motors for EU motor efficiency levels

A Europe-wide agreement will ensure that the efficiency levels of electric motors manufactured in Europe are clearly displayed. In contrast to the American legislation on motor efficiency the European agreement does not establish mandatory efficiency levels.

It basically establishes three classes giving motor manufacturers an incentive to qualify for a higher class.

ABB is one of only a handful of leading motor manufacturers in Europe to have a motor range to meet or exceed the minimum efficiencies stated in the highest level of the EU agreement of LV motors.

These efficiency levels apply to 2- and 4-pole, three phase squirrel cage induction motors rated for 400V, 50Hz with S1 duty class with the output 1.1 to 90 kW, which

account for the largest volume on the market.

The efficiency of motors from different manufacturers are collated in a database, EURODEEM, published by the European Commission. It is accessible over the Internet at <http://iamest.jrc.it/projects/eem/eurodeem.htm>.

EU efficiency classes for 2-pole motors

Output kW	2-pole Boarderline	
	EFF2/EFF3	EFF1/EFF2
1.1	76.2	82.8
1.5	78.5	84.1
2.2	81.0	85.6
3	82.6	86.7
4	84.2	87.6
5.5	85.7	88.6
7.5	87.0	89.5
11	88.4	90.5
15	89.4	91.3
18.5	90.0	91.8
22	90.5	92.2
30	91.4	92.9
37	92.0	93.3
45	92.5	93.7
55	93.0	94.0
75	93.6	94.6
90	93.9	95.0

EU efficiency classes for 4-pole motors

Output kW	4-pole Boarderline	
	EFF2/EFF3	EFF1/EFF2
1.1	76.2	83.8
1.5	78.5	85.0
2.2	81.0	86.4
3	82.6	87.4
4	84.2	88.3
5.5	85.7	89.2
7.5	87.0	90.1
11	88.4	91.0
15	89.4	91.8
18.5	90.0	92.2
22	90.5	92.6
30	91.4	93.2
37	92.0	93.6
45	92.5	93.9
55	93.0	94.2
75	93.6	94.7
90	93.9	95.0

ABB Three phase induction motors, 400 V 50 Hz - EU motor efficiency levels

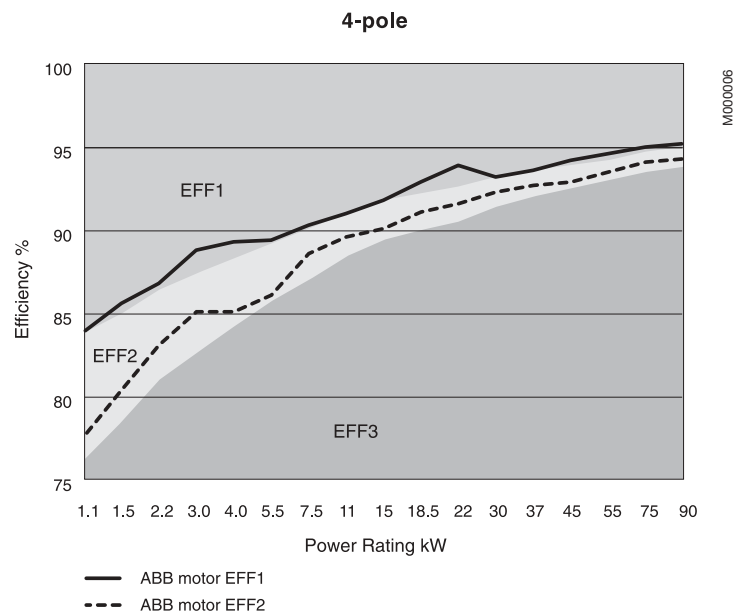
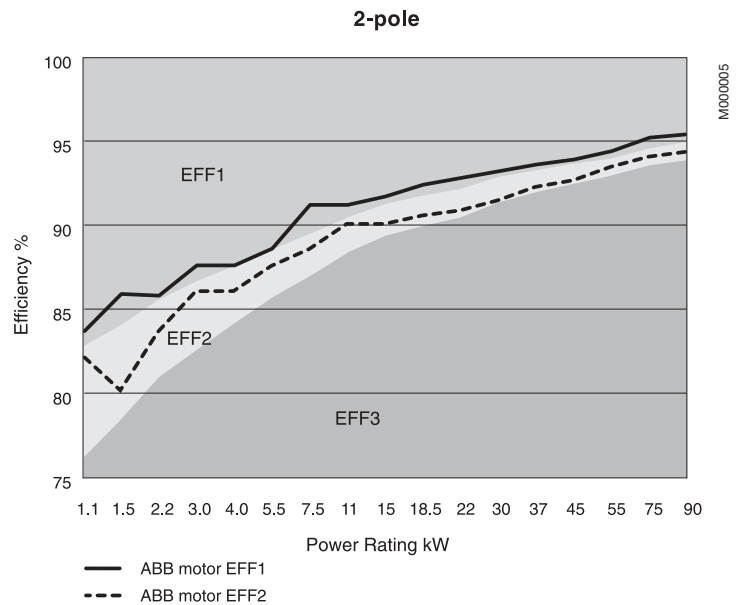

General technical specification

Mechanical and electrical design

Mounting arrangements

1

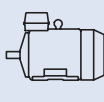
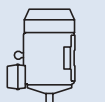
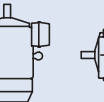
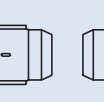
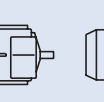
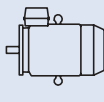
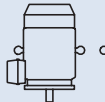
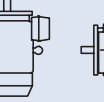
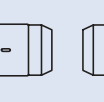
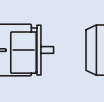
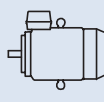
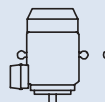
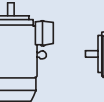
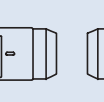
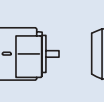
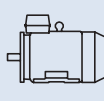
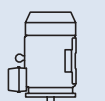
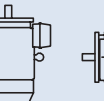
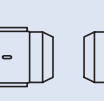
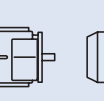
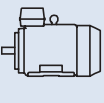
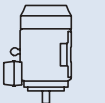
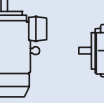
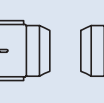
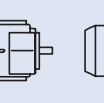
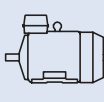
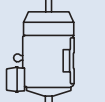
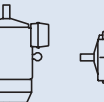
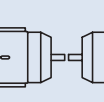
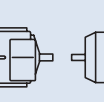
	Code/Code/Code						Product code pos. 12
Foot-mounted motor.	IM B3 IM 1001	IM V5 IM 1011	IM V6 IM 1031	IM B6 IM 1051	IM B7 IM 1061	IM B8 IM 1071	A = foot-mounted, term.box top R = foot-mounted, term.box RHS L = foot-mounted, term.box LHS
	M000007						
Flange-mounted motor, large flange	IM B5 IM 3001	IM V1 IM 3011	IM V3 IM 3031	*) IM 3051	*) IM 3061	*) IM 3071	B = flange mounted, large flange
	M000008						
Flange-mounted motor, small flange	IM B14 IM 3601	IM V18 IM 3611	IM V19 IM 3631	*) IM 3651	*) IM 3661	*) IM 3671	C = flange mounted, small flange
	M000009						
Foot- and flange-mounted motor with feet, large flange	IM B35 IM 2001	IM V15 IM 2011	IM V36 IM 2031	*) IM 2051	*) IM 2061	*) IM 2071	H = foot/flange-mounted, term.box top S = foot/flange-mounted, term.box RHS T = foot/flange-mounted, term.box LHS
	M000010						
Foot- and flange-mounted motor with feet, small flange	IM B34 IM 2101	IM V17 IM 2111	IM 2131	IM 2151	IM 2161	IM 2171	J = foot/flange-mounted, small flange
	M000011						
Foot-mounted motor, shaft with free extensions	IM 1002	IM 1012	IM 1032	IM 1052	IM 1062	IM 1072	
	M000012						

*) Not stated in IEC 60034-7.

Cooling

Designation system concerning methods of cooling refers to standard IEC 60034-6.

Example

IC 4 (A) 1 (A) 6

International Cooling ————|

Circuit arrangement ————|

0: Free circulation (open circuit)
4: Frame surface cooled

Primary coolant ————|

A for air (omitted for simplified designation)

Method of movement of primary coolant ————|

0: Free convection
1: Self-circulation
6: Machine-mounted independent component

Secondary coolant ————|

A for air (omitted for simplified designation)
W for water

Method of movement of secondary coolant ————|

0: Free convection
1: Self-circulation
6: Machine-mounted independent component
8: Relative displacement

Degrees of protection: IP code/IK code

Classification of degrees of protection provided by enclosures of rotating machines are refers to:

- Standard IEC 60034-5 or EN 60529 for IP code
- Standard EN 50102 for IK code

IP protection:

Protection of persons against getting in contact with (or approaching) live parts and against contact with moving parts inside the enclosure. Also protection of the machine against ingress of solid foreign objects. Protection of machines against the harmful effects due to the ingress of water

IP 5 5

Characteristic letter ————|

Degree of protection to persons and to parts of the motors inside the enclosure ————|

2: Motors protected against solid objects greater than 12 mm
4: Motors protected against solid objects greater than 1 mm
5: Dust-protected motors

Degree of protection provided by the enclosure with respect to harmful effects due to ingress of water ————|

3: Motors protected against spraying water
4: Motors protected against splashing water
5: Motors protected against water jets
6: Motors protected against heavy seas

IK code :

Classification of degrees of protection provided by enclosure for motors against external mechanical impacts.

IK 08

International mechanical protection ————|

Characteristic group ————|

Relation between IK code and impact energy:

IK cod	IK 0	IK 01	IK 02	IK 03	IK 04	IK 05	IK 06	IK 07	IK 08	IK 09	IK 10
Impact energy Joule	*	0.15	0.2	0.35	0.5	0.7	1	2	5	10	20
									ABB Standard		

* not protected according to EN 50102

Insulation

ABB uses class F insulation systems, which, with temperature rise B, is the most common requirement among industry today.

The use of Class F insulation with Class B temperature rise gives ABB products a 25° C safety margin. This can be used to increase the loading by up to 12 per cent for limited periods, to operate at higher ambient temperatures or altitudes, or with greater voltage and frequency tolerances. It can also be used to extend insulation life. For instance, a 10 K temperature reduction will extend the insulation life.

Class F insulation system

- Max ambient temperature 40° C
- Max permissible temperature rise 105 K
- Hotspot temperature margin + 10 K

Class B rise

- Max ambient temperature 40° C
- Max permissible temperature rise 80 K
- Hotspot temperature margin + 10 K

Insulation system temperature class

- Class F 155° C
- Class B 130° C
- Class H 180° C

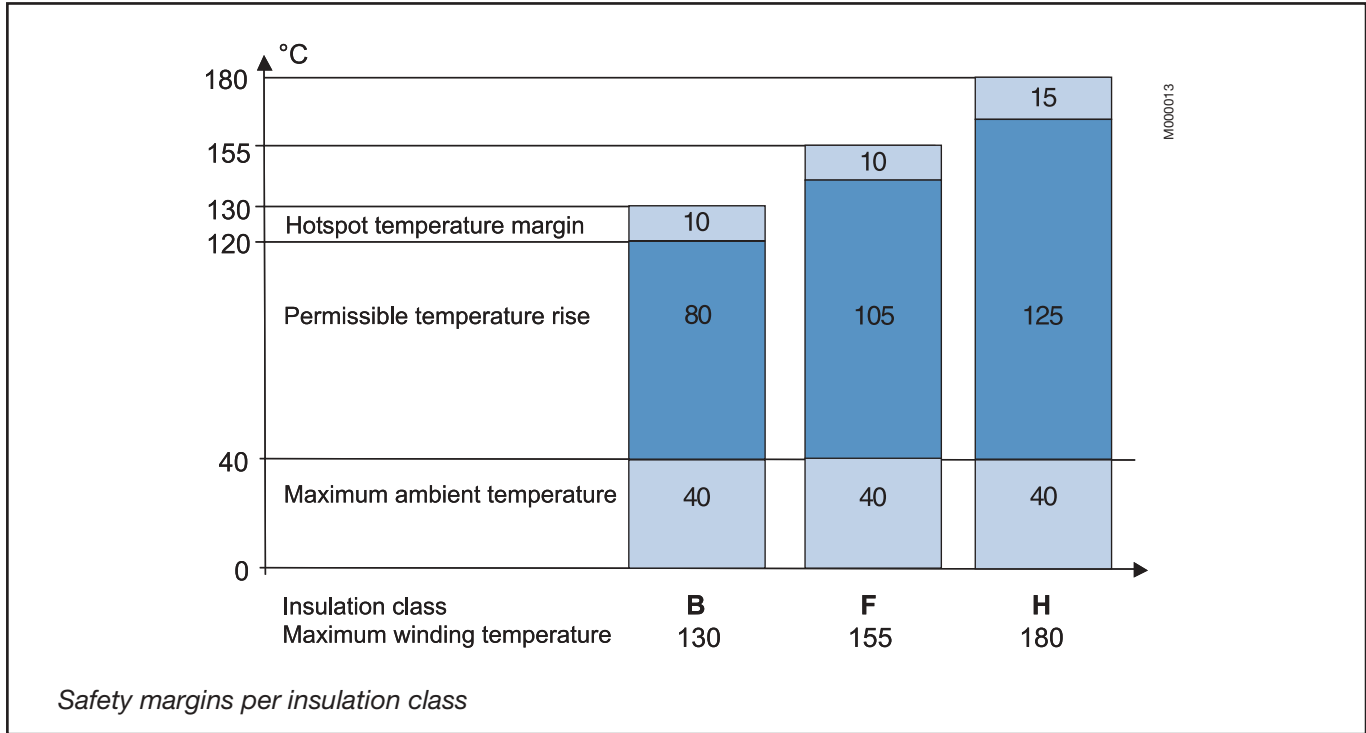

Frequency converter drives

Squirrel cage induction motors offer excellent availability, reliability and efficiency. With a frequency converter – a variable speed drive (VSD) – the motor will deliver even better value. A variable speed drive motor can be started softly with low starting current, and the speed can be controlled and adjusted to suit the application demand without steps over a wide range. Also the use of a frequency converter together with a squirrel cage motor usually leads to remarkable energy and environmental savings.

However, all motors are not suitable for variable speed drive. There are several points that have to be taken into account in the design and selection of the motor, if it is intended for variable speed operation.

Within the General purpose motor range ABB offers motors designed for both Direct On Line (DOL) and variable speed applications.

For more demanding applications the use of ABB Process performance motors is recommended.

When selecting general purpose motors to variable speed drives, following points shall be taken into consideration:

1. Dimensioning

The voltage (or current) fed by the frequency converter is not purely sinusoidal. This may increase the losses, vibration, and noise of the motor. Furthermore, a change in the distribution of the losses may affect to the temperature rise of the motor. In each case, the motor must be correctly sized according to the instructions supplied with the selected frequency converter.

When using ABB converters, please use ABB's DriveSize dimensioning programme or the loadability curves of the corresponding converter type for sizing the motors. The loadability curve for applicable General purpose motors used with ABB's ACS 800- frequency converters with DTC-control can be found in figure 3.

2. Speed range

In a frequency converter drive, the actual operating speed of the motor may deviate considerably from its nominal speed (i.e. the speed stamped on the rating plate).

For higher speeds, ensure that the highest permissible rotational speed of the motor or the critical speed of the entire equipment is not exceeded. When high speed operation exceeds the nominal speed of the motor, the following points should be checked:

- Maximum torque of the motor
- Bearing construction
- Lubrication
- Balancing
- Critical speeds
- Shaft seals
- Ventilation
- Fan noise

Guideline values of maximum speeds for General purpose aluminum motors described in figure 1. Exact values are available on request.

Figure 1. Guideline values of maximum speeds for General purpose motor in aluminum frame:

Motor size	Speed r/min	
	2-pole	4-pole
63-80	6000	4500
90-100	6000	6000
112-200	4500	4500
225-280	3600	3600

At low speed operation the cooling capacity of the fan decreases, which may cause higher temperature rises in the motor. A separate constant speed fan can be used to increase cooling capacity and loadability at low speed. It is also important to check the performance of the grease at low speeds.

3. Lubrication

Variable speed operation affects on the bearing temperature, which must be taken into account when selecting the lubrication method and grease type. For example the life time of sealed bearings can be remarkably shorter than in direct on line operation.

4. Insulation protection

Frequency converter supply causes higher voltage stresses at the windings of the motor than the sinusoidal supply. Thus, the insulation system and possible filters must be selected according to the used voltage and converter type. For selection of insulation system and filters, see figure 2.

5. Bearing currents

Bearing voltages and currents must be avoided in all motors. For reliability issues, insulated bearings and/or properly dimensioned filters at the converter output must be used according to the instructions in figure 2. When ordering, clearly state which alternative will be used.

For more information about bearing currents and voltages, please contact ABB.

6. Cabling, grounding and EMC

The use of a frequency converter puts higher demands on the cabling and grounding of the drive system. The motor must be cabled by using shielded symmetrical cables and cable glands providing 360° bonding (also called EMC-glands). For motors up to 30 kW unsymmetrical cables can be used, but shielded cables are always recommended.

More information about grounding and cabling of a variable speed drive can be found from the manual

“Grounding and cabling of the drive system” (Code: 3AFY 61201998 R0125 REV B) and the ABB’s Low Voltage Motors Manual.

For fulfilling the EMC requirements, special EMC cable(s) must be used in addition to the correct cable gland mounting, with special, extra earthing pieces. Please refer to the manuals of the frequency converter.

Validity of figure 2

Measures mentioned in Figure 2 apply to the applicable motors within the General motors range (not high-output versions) with ACS 800 and ACS 550 drives with uncontrolled DC-voltage. For other alternatives and converter types, please contact ABB.

Figure 2. Selection rules for insulation and filtering in variable speed drives

	Motor nominal power P_N or frame size		
	$P_N < 100 \text{ kW}$	$P_N \geq 100 \text{ kW}$ or IEC 315 \leq Frame size \leq IEC 355	$P_N \geq 350 \text{ kW}$ or IEC 400
$U_N \leq 500 \text{ V}$	Standard motor	Standard motor + Insulated N-bearing	Standard motor + Insulated N-bearing + Common mode filter
$U_N \leq 600 \text{ V}$	Standard motor + dU/dt-filter (reactor) OR Reinforced insulation	Standard motor + dU/dt-filter (reactor) + Insulated N-bearing OR Reinforced insulation + Insulated N-bearing	Standard motor + Insulated N-bearing + dU/dt-filter (reactor) + Common mode filter OR Reinforced insulation + Insulated N-bearing + Common mode filter
$U_N \leq 690 \text{ V}$	Reinforced insulation + dU/dt-filter (reactor)	Reinforced insulation + dU/dt-filter (reactor) + Insulated N-bearing	Reinforced insulation + Insulated N-bearing + dU/dt-filter (reactor) + Common mode filter

dU/dt filter (reactor)

Series reactor. DU/dt -filter decreases the changing rate of the phase and main voltages and thus reduces voltage stresses in the windings. DU/dt -filters also decrease so-called common mode currents and the risk of bearing currents.

Common mode

Common mode filters reduce so-called common mode currents in VSD applications and thus decrease the risk of bearing currents. Common mode filters do not significantly affect the phase or main voltages on the motor terminals.

Insulated Bearings

Bearings with insulated inner or outer races are used as the standard solution. So-called hybrid bearings, i.e. bearings with non-conductive ceramic balls, can also be used in special applications. More information for spare part selection is available on request.

Figure 3. Motor loadability with ACS 800, Field weakening point 50 Hz.

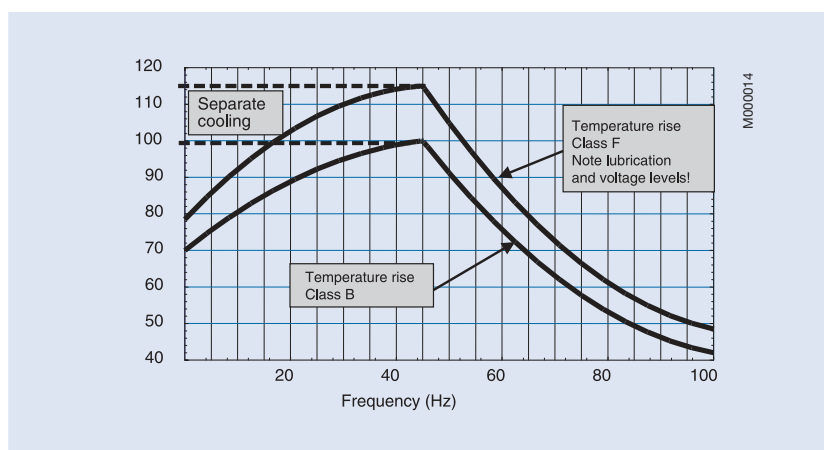

General Purpose Open Drip Proof Motors

Open drip proof squirrel cage three phase
low voltage motors,
Sizes 280 - 400, 110 to 800 kW

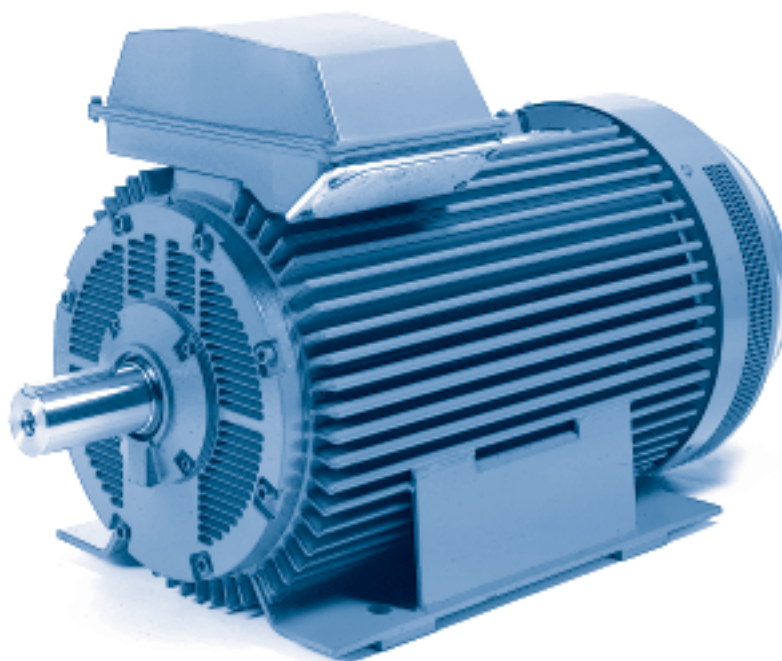

www.abb.com/motors&drives

- > Motors
- > Low voltage motors
- > General purpose motors

Mechanical design	146
Ordering information.....	151
Technical data.....	152
Variant codes	157
Dimension drawings.....	159
Rating plates	163
Open drip proof motors in brief	164

Mechanical design

Stator

The stator frame is made of profile-pressed sheet steel, giving the motor high mechanical strength, low weight and a good surface finish. The stator core is welded into the stator frame and contributes to its excellent mechanical properties.

Feet and lifting eyes are welded to the stator frame. The terminal box and end shields are of cast iron.

Drain holes

Motors that will be operated in very humid or wet environments, and especially under intermittent duty, should be provided with drain holes. The appropriate IM designation, such as IM V3 (IM 3031), is specified, on the basis of the method of motor mounting.

M2FA motors are fitted with drain holes and plugs. The

plugs are open on delivery. Check that the drain holes and grease outlet face downwards, when mounting designation differs from standard horizontal mounting.

In the case of vertical mounting, the upper plug must be hammered home completely. In very dusty environments the drain hole plug should be knocked in.

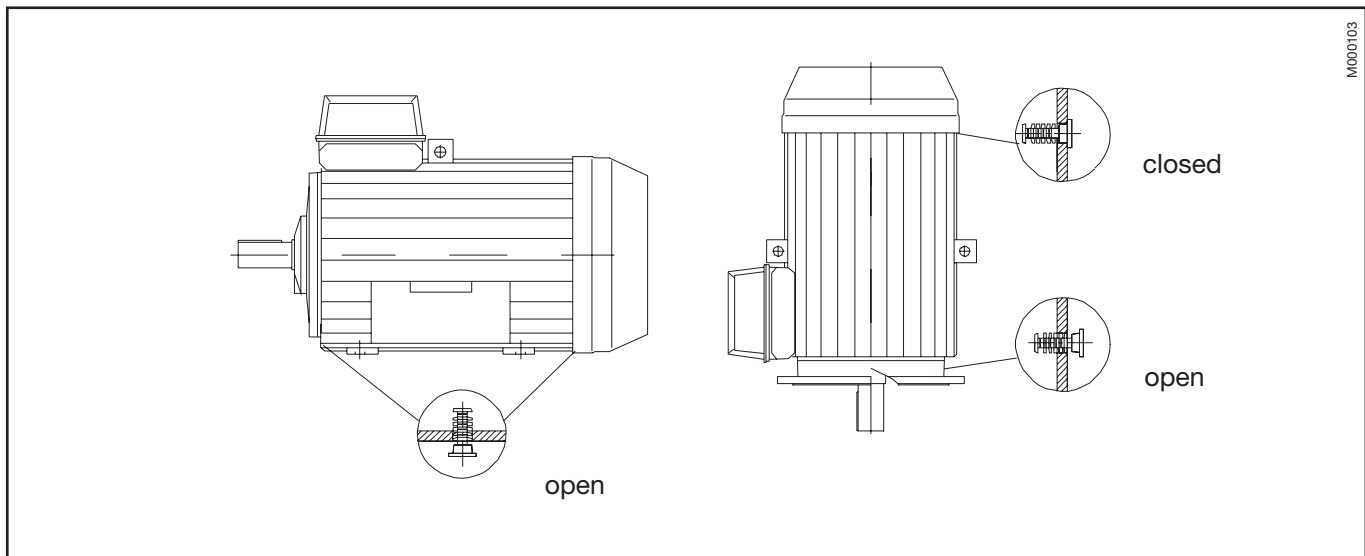

Terminal box

Terminal boxes are mounted either on the top of the motor, or on either side of the motor, see ordering information page .

In basic version the terminal box can be rotated 2x180° to allow cable entry from either side of the motor.

The terminal box is equipped with cable glands or cable boxes as standard, and terminations are suitable for Cu- and Al-cables. Cables are connected to the terminals by cable lugs which are not included with the motor.

To enable us to supply suitable terminations for the motor please state cable type, quantity and size when ordering.

For dimension drawings of terminal boxes, see drawings.

Co-ordination of terminal boxes and cable entries

If no ordering information on the cable is given, it is assumed to be p.v.c. -insulated type and termination parts are supplied according to the table below and on next page.

Deviations from standard design according to the following tables are available on request.

M2FA 280 to 400 motors with top-mounted terminal box

Standard cable entries and cable boxes

Voltage 380 - 690 V, 50 Hz

Motor size M2CA	Ter- minal box	Flange or adapter	Cable box or cable gland	Gland thread	Cable diameter	Max. connection cable area mm ²	Terminal bolt size	Voltage/ freq. code
3000 r/min (2 poles)								
280	122/4	3GZF 294730-749	2x 3GZF 294730-613		2x Ø32-49	2x150	M12	
315	142/4	3GZF 294730-753	2x 3GZF 294730-613		2x Ø32-49	2x240	M12	
355 SA	142/4	3GZF 294730-753	2x 3GZF 294730-613		2x Ø32-49	2x240	M12	
355 M ₋	162/4	3GZF 294730-944	3GZF 294730-301		2x Ø48-60	4x240	M12	D
	142/4	-	3GZF 294730-301		2x Ø48-60	2x240	M12	E
355 L ₋	162/4	3GZF 294730-944	3GZF 294730-301		2x Ø48-60	4x240	M12	
1500 r/min (4 poles)								
280	122/4	3GZF 294730-749	2x 3GZF 294730-613		2x Ø32-49	2x150	M12	
315	142/4	3GZF 294730-753	2x 3GZF 294730-613		2x Ø32-49	2x240	M12	
355 S ₋	142/4	3GZF 294730-753	2x 3GZF 294730-613		2x Ø32-49	2x240	M12	
355 M ₋	162/4	3GZF 294730-944	3GZF 294730-301		2x Ø48-60	4x240	M12	D
	142/4	-	3GZF 294730-301		2x Ø48-60	2x240	M12	E
355 LA	162/4	3GZF 294730-944	3GZF 294730-301		2x Ø48-60	4x240	M12	
355 LKD	162/4	3GZF 294730-944	3GZF 294730-501		2x Ø60-80	4x240	M12	
400 LKA	162/9	3GZF 294730-944	3GZF 294730-501		2x Ø60-80	4x240	M12	D
	162/4	3GZF 294730-944	3GZF 294730-501		2x Ø60-80	4x240	M12	E
400 LKB	162/9	3GZF 294730-944	3GZF 294730-501		2x Ø60-80	4x240	M12	
1000 r/min (6 poles)								
280	122/4	3GZF 294730-749	2x 3GZF 294730-613		2x Ø32-49	2x150	M12	
315	142/4	3GZF 294730-753	2x 3GZF 294730-613		2x Ø32-49	2x240	M12	
355 S ₋	142/4	3GZF 294730-753	2x 3GZF 294730-613		2x Ø32-49	2x240	M12	
750 r/min (8 poles)								
280	122/4	3GZF 294730-749	2x 3GZF 294730-613		2x Ø32-49	2x150	M12	
315	142/4	3GZF 294730-753	2x 3GZF 294730-613		2x Ø32-49	2x240	M12	
355 S ₋	142/4	3GZF 294730-753	2x 3GZF 294730-613		2x Ø32-49	2x240	M12	

Voltage/frequency codes:

D - 380-420 VD 50 Hz, 660-690 VY 50 Hz, 440-480 VD 60 Hz

E - 500 VD 50 Hz, 575 VD 60 Hz

Examples:

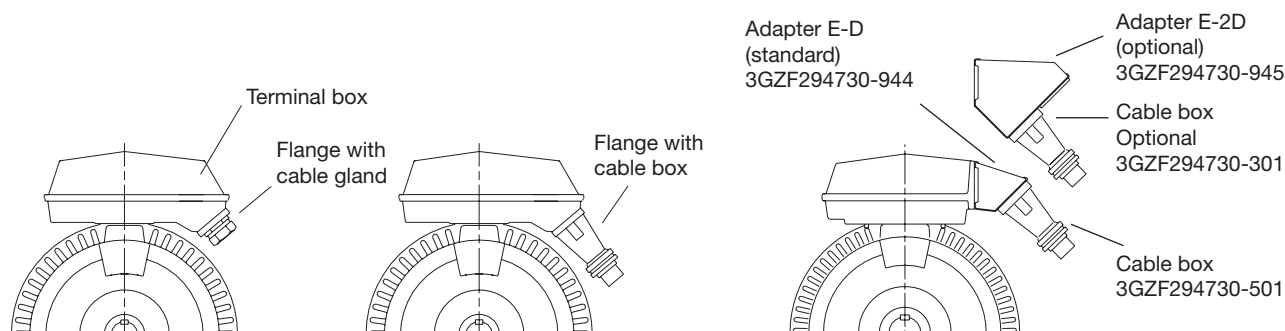

M000065

Alternatives for cable entries and cable boxes

The tables on previous pages show the standard terminal boxes and termination parts that are delivered when no information on the cable is given.

The table below shows the different alternatives avail-

able for cable boxes and cable entries. Other types on request.

Motor size	Terminal box	Opening type	Max. rate current A (Y/D-conn.)	Max. size of conductor mm ²	Cable entry mm	Cable box	Blank plate
280	122/4	C (FL21)	210/360	2x150	1xPg29...42 2xPg29...42	1xØ36...52/Ø48...60 1xØ36...52/Ø48...60	MKLN 20
315	142/4	D (FL33)	370/640	2x185	1xPg36...42 2xPg36...48	1xØ36...52/Ø48...60 2xØ48...60/Ø50...68	MKLN 30
355, 400	142/4	D (FL33)	370/640	2x240	1xPg36...42 2xPg36...48	1xØ36...52/Ø48...60 2xØ48...60/Ø50...68	MKLN 30
	162/4	E-D ¹⁾	550/950	4x240	1xPg36...42 2xPg36...48	1xØ36...52/Ø48...60 2xØ48...60/Ø50...68 2x2Ø68...80	
		E-2D ¹⁾	550/950	4x240	2x1Pg36...42 2x2Pg36...48	2x1xØ36...52/Ø48...60 2x2xØ48...60/Ø50...68 2x2Ø68...80	

¹⁾ Terminal box type 162/4 is used with a combination of one E-opening and one or two D-openings, as described below:

Terminal box 162 with adapting flange 3GZF 294730-501 (E-D) or optional 3GZF 294730-301 (E-2D):

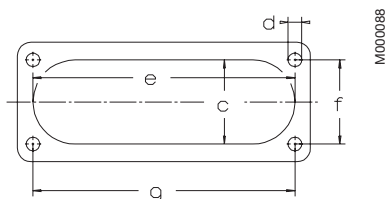
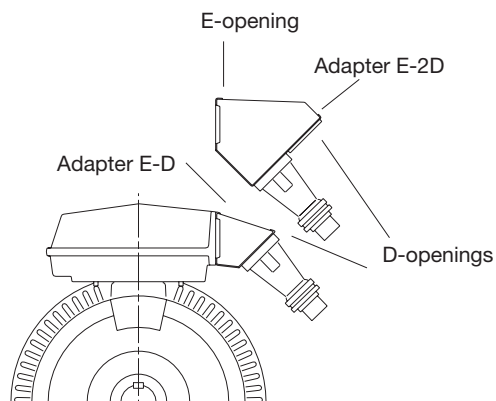

Terminal box 162 with adapting flange:

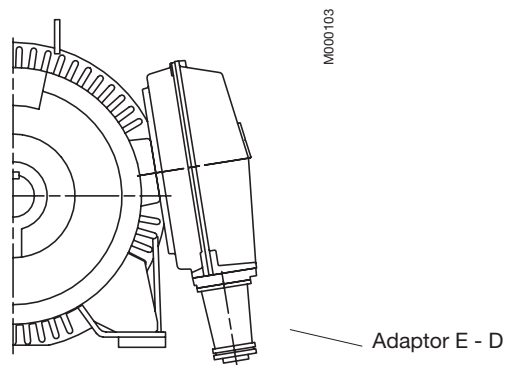

Opening	c	e	f	g	d
C (FL 21)	62	193	62	193	M8
D (FL 33)	100	300	80	292	M10
E (FL 40)	115	370	100	360	M12

Bearings

The motors are normally fitted with single-row deep groove ball bearings as listed in the table on the right. The complete ball bearing designation is stated on the rating plate.

If the bearing at the D-end is replaced with a roller bearing (NU- or NJ-), higher radial forces can be handled. Roller bearings are suitable for belt drive applications.

When there are high axial forces, angular-contact ball bearings should be used. This option is available on request. When a motor with angular-contact ball bearings is ordered, the method of mounting and direction and magnitude of the axial force must be specified. For special bearings, please see variant codes.

Standard bearing types

Motor size	Number of poles	Basic version with deep groove ball bearings		Version with roller bearings, variant code 037
		D-end	N-end	D-end
280	2	6316/C4	6316/C4	-
	4-8	6319/C3	6316/C3	(NU 319/C3)
315	2	6316/C4	6316/C4	-
	4-8	6319/C3	6316/C3	(NU319/C3)
355	2 ¹⁾	-	-	-
	4-8	6322/C3	6319/C3	(NU 322/C3)
400	4	6322/C3	6319/C3	(NU 322/C3)

¹⁾ Please check technical construction with ABB.

Bearing seals

M2FA motors have, as standard, V-rings at both ends. The size and type of suitable seals are in accordance with the table below:

Motor size	Number of poles	d ₁	d ₂	B ₁	b	Standard design Axial seal		Alternative design Radial seal (DIN 3760)
						D-end	N-end	
280	2	80	100	13.5	10	VS 80	VS 80	80x100x10 ¹⁾
	4-8	95	120	13.5	12	VS 80	VS 80	95x120x12
315	2	80	100	13.5	10	VS 80	VS 80	80x100x10 ¹⁾
	4-8	95	120	13.5	12	VS 95	VS 80	95x120x12
355	2	95	120	13.5	12	VS 95	VS 95	95x120x12 ¹⁾
	4-8	110	140	15.5	12	VS 110	VS 95	110x140x12 ¹⁾
400	4-8	110	140	15.5	12	VS 110	VS 95	110x140x12 ¹⁾

¹⁾ Viton-seal

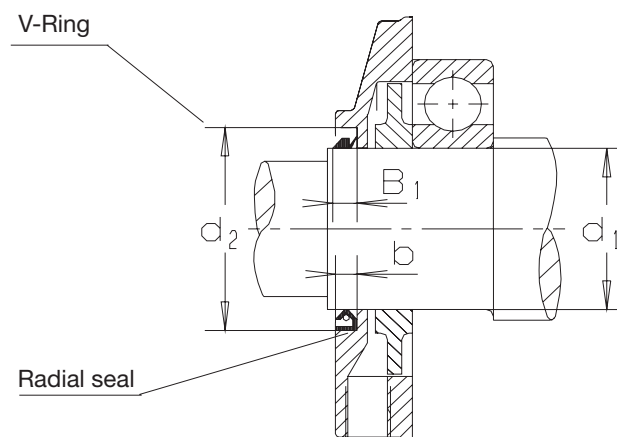

Permissible radial forces

The table below gives the permissible radial force in Newtons, assuming zero axial force. The values are based on normal conditions at 50 Hz and calculated bearing lives of 40,000 h.

At 60 Hz the values must be reduced by 10 %. For two-speed motors, the values must be based on the higher speed. Permissible loads of simultaneous radial and axial forces will be supplied on request.

Motors are B3 version with force directed sideways. In some cases the strength of the shaft affects the permissible forces.

Permissible radial and axial force for a bearing life of 40,000 hours

Motor size	Number of poles	Length of shaft extension E (mm)	Permissible radial force for:				Permissible axial force for ¹⁾ :		
			Horizontal mounting, sideways direction of force		Horizontal mounting, sideways direction of force		Horizontal mounting	Vertical mounting with shaft extension downwards	
			Ball bearing at point of application:		Roller bearing at point of application:		Direction of force		
			FX ₀ N	FX _{max} N	FX ₀ N	FX _{max} N	Outwards N	Upwards N	Downwards N
280	2	140	5850	4500	–	–	3800	7150	2250
	4	170	8900	7050	26100	11400	5300	8800	3800
	6	170	10200	8100	29500	11300	6500	10100	4700
	8	170	11200	8900	32100	11100	7450	11200	5500
315	2	140	5800	4800	–	–	3700	7450	1800
	4	170	9000	7300	26200	14000	5000	9250	2750
	6	170	10200	8350	29600	14200	6350	10800	3300
	8	170	11300	9200	32300	14300	7300	12200	4300
355	2	140	6200	5400	–	–	2100	²⁾	²⁾
	4	210	12100	9800	36500	18100	4100	²⁾	²⁾
	6	210	13800	11200	41500	20200	5500	²⁾	²⁾
	8	210	15200	12300	45000	21000	6900	²⁾	²⁾
400	2	170	²⁾	²⁾	–	–	²⁾	²⁾	²⁾
	4	210	12200	10500	37500	13500	3900	²⁾	²⁾
	6	210	²⁾	²⁾	²⁾	²⁾	²⁾	²⁾	²⁾
	8	210	²⁾	²⁾	²⁾	²⁾	²⁾	²⁾	²⁾

¹⁾ Flange-mounted motors with deep groove ball bearings at D-end. Other designs on request. No simultaneous radial forces allowed.

²⁾ On request.

If the radial force is applied between points X₀ and X_{max}, the permissible force F_R can be calculated from the following formula:

$$F_R = F_{x_0} - \frac{X}{E} (F_{x_0} - F_{x_{max}})$$

E = length of shaft extension in basic version

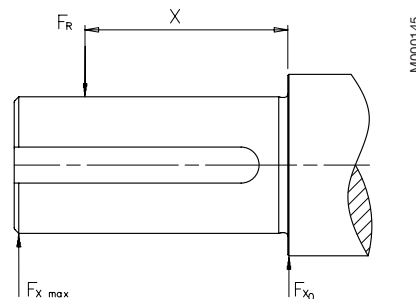

Ordering information

Sample order

When placing an order, please state the following minimum data in the order, as in the example.

The product code of the motor is composed in accordance with the following example.

Motor type	M2FA 315SMA
Pole number	2
Mounting arrangement (IM-code)	IM B3 (IM 1001)
Rated output	200 kW
Product code	3GFA312210-ASB
Variant codes if needed	

A	B	C	D,E,F, G	A Motor type
M2FA	315	SMA	3GFA 312 210 - ADA, 003 etc.	B Motor size
		1 - 4	5-6 7 8-10 11 12 13 14	C Product code
				D Mounting arrangement code
				E Voltage and frequency code
				F Generation code
				G Variant codes

Explanation of the product code:

Positions 1 to 4

3GFA = Open drip proof squirrel cage three phase motor with steel frame

Positions 5 and 6

IEC-frame size

28 = 280 **35** = 355

31 = 315 **40** = 400

Position 7

Speed (pole pairs)

1 = 2 poles **6** = 8 poles

2 = 4 poles **7** => 12 poles

3 = 6 poles **8** = Two-speed motors

4 = 8 poles **9** = Multi-speed motors

5 = 10 poles

Position 8 to 10

Serial number

Position 11

- (dash)

Position 12

Mounting arrangement

A = Foot-mounted, top-mounted terminal box

L = Foot-mounted, terminal box LHS, seen from D-end

R = Foot-mounted, terminal box RHS, seen from D-end

B = Flange-mounted

L = Foot-mounted, terminal box LHS, seen from D-end

R = Foot-mounted, terminal box RHS, seen from D-end

H = Foot- and flange-mounted, top-mounted terminal box

S = Foot- and flange-mounted, terminal box LHS seen from D-end

T = Foot- and flange-mounted, terminal box RHS seen from D-end

Position 13

Voltage/frequency code

See tables below

Position 14

Generation code

A, B, C...

The product code must, if needed, followed by variant codes.

Code letters for supplementing the product code for voltage and frequency – single speed motors:

A	B	D	E	F	H
380 VY 50 Hz	380 VΔ 50 Hz	380-420 VΔ 50 Hz 660-690 VY 50 Hz 440-480 VΔ 60 Hz	500 VΔ 50 Hz 575 VΔ 60 Hz	500 VY 50 Hz 575 VY 60 Hz	415 VΔ 50 Hz
S	T	U	X		
220-240 VΔ 50 Hz 380-420 VY 50 Hz 440-480 VY 60 Hz	660 VΔ 50 Hz	690 VΔ 50 Hz	Other rated voltage, connection or frequency, max. 690 V		

Code letters for supplementing the product code for voltage and frequency – two-speed motors:

A	B	D	E	H	S
220 V 50 Hz	380 V 50 Hz	380-400 V 50 Hz 440-480 V 60 Hz	500 V 50 Hz 575 V 60 Hz	400-415 V 50 Hz 460-480 V 60 Hz	220-230 V 50 Hz

General purpose open drip proof motors

Technical data for squirrel cage

three phase motors, steel frame

IP 23 S – IC 01 – Insulation class F, temperature rise class B

Output kW	Motor type	Product code	r/min	Efficiency Speed %	Power factor 100%	Current		Torque		
						I_N cos φ A	I_s I_N	T_N Nm	T_s T_N	T_{max} T_N
3000 r/min = 2 poles			400 V 50 Hz			Basic design				
132	²⁾ M2FA 280 SMA	3GFA 281 210-••A	2971	94.5	0.84	241	7.0	424	2.1	2.4
160	M2FA 315 SA	3GFA 311 110-••A	2977	94.2	0.86	289	6.7	513	1.6	2.5
200	M2FA 315 SMA	3GFA 311 210-••A	2975	94.4	0.86	353	7.1	643	1.8	2.6
250	M2FA 315 MB	3GFA 311 320-••A	2975	94.5	0.87	431	7.1	804	1.9	2.6
315	M2FA 315 MC	3GFA 311 330-••A	2977	94.6	0.84	573	7.8	1012	2.1	2.8
355	¹⁾ M2FA 315 LA	3GFA 311 510-••A	2969	94.9	0.89	606	6.8	1142	2.0	2.5
400	M2FA 315 LB	3GFA 311 520-••A	2969	94.8	0.88	700	7.3	1288	2.0	2.6
400	⁵⁾ M2FA 355 SA	3GFA 351 110-••A	2982	94.7	0.88	680	7.1	1280	1.1	2.6
450	⁵⁾ M2FA 355 MA	3GFA 351 310-••A	2978	95.0	0.89	765	7.4	1443	1.3	3.0
500	⁵⁾ M2FA 355 MB	3GFA 351 320-••A	2973	95.1	0.90	851	6.7	1606	1.2	2.7
560	⁵⁾ M2FA 355 LA	3GFA 351 510-••A	2981	95.5	0.89	956	8.7	1794	1.5	3.1
3000 r/min = 2 poles			400 V 50 Hz			High-output design				
160	M2FA 280 MB	3GFA 281 320-••A	2971	94.9	0.88	279	7.0	514	2.0	2.7
1500 r/min = 4 poles			400 V 50 Hz			Basic design				
110	M2FA 280 SA	3GFA 282 110-••A	1476	93.1	0.83	211	5.8	713	1.8	2.4
132	M2FA 280 SMA	3GFA 282 210-••A	1477	93.8	0.84	245	5.9	853	1.8	2.3
160	M2FA 315 SA	3GFA 312 110-••A	1483	94.6	0.83	297	6.5	1030	1.8	2.5
200	M2FA 315 SMA	3GFA 312 210-••A	1482	94.7	0.83	366	6.5	1287	1.8	2.3
250	M2FA 315 MB	3GFA 312 320-••A	1481	94.9	0.83	452	6.7	1611	1.7	2.3
315	¹⁾ M2FA 315 LA	3GFA 312 510-••A	1477	94.5	0.83	577	6.7	2036	2.2	2.5
315	M2FA 355 SA	3GFA 352 110-••A	1484	95.0	0.85	555	6.4	2027	1.7	2.4
355	²⁾ M2FA 355 SB	3GFA 352 120-••A	1485	95.4	0.82	653	6.6	2282	1.9	2.5
400	²⁾ M2FA 355 SC	3GFA 352 130-••A	1484	95.3	0.82	733	5.9	2574	1.7	2.2
450	²⁾ M2FA 355 MA	3GFA 352 310-••A	1485	95.4	0.83	810	6.5	2896	1.8	2.4
500	¹⁾²⁾ M2FA 355 LA	3GFA 352 510-••A	1486	95.4	0.81	920	7.7	3213	2.0	2.8
600	M2FA 355 LKD	3GFA 352 540-••A	⁴⁾							
710	M2FA 400 LKA	3GFA 402 510-••A	⁴⁾							
800	M2FA 400 LKB	3GFA 402 520-••A	⁴⁾							
1500 r/min = 4 poles			400 V 50 Hz			High-output design				
160	M2FA 280 MB	3GFA 282 320-••A	1480	94.0	0.81	305	7.2	1032	2.5	2.6

The two bullets in the product code indicate choice of mounting arrangement, voltage and frequency (see ordering information page).

- ¹⁾ Temperature rise class F.
- ²⁾ Special winding for 415V 50 Hz.
- ³⁾ 415 V 50 Hz and 440 V 60 Hz on request.
- ⁴⁾ On request.
- ⁵⁾ Please check technical construction with ABB.

General purpose open drip proof motors

Technical data for squirrel cage

three phase motors, steel frame

IP 23 S – IC 01 – Insulation class F, temperature rise class B

Output kW	Motor type	Speed r/min	Efficiency %	Power factor cos φ	Current I _N A	Speed r/min	Efficiency %	Power factor cos φ	Current I _N A	Moment of inertia J = ¼ GD ² kgm ²	Weight kg	Sound pressure level L _p dB(A)
3000 r/min = 2 poles		380 V 50 Hz				415 V 50 Hz				Basic design		
132 ²⁾	M2FA 280 SMA	2969	94.4	0.86	246	2966	94.1	0.87	227	0.8	540	87
160	M2FA 315 SA	2975	94.2	0.87	302	2978	94.2	0.84	282	1.2	695	92
200	M2FA 315 SMA	2974	94.3	0.87	370	2978	94.4	0.84	344	1.4	770	92
250	M2FA 315 MB	2974	94.4	0.88	449	2976	94.5	0.85	420	1.7	840	92
315	M2FA 315 MC	2974	94.6	0.86	576	2971	94.6	0.88	530	1.7	840	92
355 ¹⁾	M2FA 315 LA	2965	94.8	0.89	635	2970	94.9	0.86	591	2.1	975	92
400	M2FA 315 LB	2966	94.7	0.88	720	2970	94.8	0.85	683	2.1	975	92
400 ⁵⁾	M2FA 355 SA	2980	94.6	0.90	700	2983	94.7	0.87	663	3.2	1220	93
450 ⁵⁾	M2FA 355 MA	2975	94.9	0.90	795	2979	95.0	0.87	746	3.5	1320	93
500 ⁵⁾	M2FA 355 MB	2970	95.1	0.90	880	2974	95.1	0.87	830	3.5	1320	93
560 ⁵⁾	M2FA 355 LA	2978	95.5	0.90	980	⁴⁾				4.8	1530	93
3000 r/min = 2 poles		380 V 50 Hz				415 V 50 Hz				High-output design		
160	M2FA 280 MB	2968	94.8	0.88	288	2973	94.9	0.86	269	1.15	580	89
1500 r/min = 4 poles		380 V 50 Hz				415 V 50 Hz				Basic design		
110	M2FA 280 SA	1474	92.8	0.85	217	1477	93.1	0.82	206	1.15	445	81
132	M2FA 280 SMA	1474	93.2	0.86	255	1478	93.8	0.83	239	1.4	490	81
160	M2FA 315 SA	1481	94.5	0.85	306	1481	94.6	0.84	283	2	680	86
200	M2FA 315 SMA	1480	94.6	0.85	379	1483	94.8	0.82	360	2.3	735	86
250	M2FA 315 MB	1479	94.7	0.86	470	1482	94.9	0.83	441	2.9	850	86
315 ¹⁾	M2FA 315 LA	1475	94.5	0.85	596	1473	93.5	0.86	540	3.5	970	87
315	M2FA 355 SA	1482	94.8	0.86	584	1485	95.0	0.83	541	5.5	1220	89
355 ²⁾	M2FA 355 SB	1484	95.3	0.84	670	1485	95.4	0.83	622	5.5	1220	89
400 ²⁾	M2FA 355 SC	1482	95.2	0.85	746	1483	95.1	0.84	685	5.5	1220	89
450 ²⁾	M2FA 355 MA	1483	95.3	0.85	835	1484	95.4	0.83	798	6.5	1350	89
500 ¹⁾²⁾	M2FA 355 LA	1484	95.3	0.84	949	1486	95.4	0.83	880	7.8	1550	89
600	M2FA 355 LKD	⁴⁾								9.8	1820	
710	M2FA 400 LKA	⁴⁾									2700	
800	M2FA 400 LKB	⁴⁾									2700	
1500 r/min = 4 poles		380 V 50 Hz				415 V 50 Hz				High-output design		
160	M2FA 280 MB	1478	93.9	0.84	310	1481	94.0	0.81	298	1.7	550	87

The two bullets in the product code indicate choice of mounting arrangement, voltage and frequency (see ordering information page).

- ¹⁾ Temperature rise class F.
- ²⁾ Special winding for 415V 50 Hz.
- ³⁾ 415 V 50 Hz and 440 V 60 Hz on request.
- ⁴⁾ On request.
- ⁵⁾ Please check technical construction with ABB.

General purpose open drip proof motors

Technical data for squirrel cage

three phase motors, steel frame

IP 23 S – IC 01 – Insulation class F, temperature rise class B

Output kW	Motor type	Product code	r/min	Efficiency Speed %	Power factor 100%	Current		Torque			
						I_N cos φ A	I_s I_N	T_N Nm	T_s T_N	T_{max} T_N	
1000 r/min = 6 poles			400 V 50 Hz			Basic design					
75	M2FA 280 SA	3GFA 283 110-••A	987	92.8	0.76	155	5.8	725	1.9	2.2	
90	¹⁾ M2FA 280 SMA	3GFA 283 210-••A	987	93.1	0.76	187	6.1	870	2.0	2.3	
110	M2FA 315 SA	3GFA 313 110-••A	988	93.5	0.81	210	7.4	1062	1.7	2.6	
132	M2FA 315 SMA	3GFA 313 210-••A	988	94.0	0.83	248	7.6	1275	1.8	2.7	
160	M2FA 315 MB	3GFA 313 320-••A	988	94.1	0.82	300	8.2	1545	1.9	2.8	
185	¹⁾ M2FA 315 LA	3GFA 313 510-••A	987	94.4	0.83	346	8.5	1788	1.9	2.9	
200	M2FA 355 SA	3GFA 353 110-••A	990	94.7	0.82	373	7.1	1927	1.6	2.5	
250	M2FA 355 SB	3GFA 353 120-••A	990	94.8	0.83	457	7.3	2409	1.6	2.5	
300	M2FA 355 MA	3GFA 353 310-••A	990	95.1	0.81	541	7.2	2894	1.7	2.4	
1000 r/min = 6 poles			400 V 50 Hz			High-output design					
110	¹⁾ M2FA 280 MB	3GFA 283 320-••A	987	93.6	0.76	227	6.5	1063	2.1	2.3	
750 r/min = 8 poles			400 V 50 Hz			Basic design					
55	M2FA 280 SA	3GFA 284 110-••A	738	91.2	0.78	117	5.6	711	1.2	2.0	
75	¹⁾ M2FA 280 SMA	3GFA 284 210-••A	738	91.8	0.76	161	6.1	970	1.4	2.1	
90	M2FA 315 SMA	3GFA 314 210-••A	739	92.9	0.79	183	6.8	1162	1.7	2.5	
110	M2FA 315 MB	3GFA 314 320-••A	739	93.4	0.78	224	7.3	1420	1.8	2.6	
132	¹⁾ M2FA 315 LA	3GFA 314 510-••A	739	93.3	0.78	268	7.2	1706	1.8	2.6	
150	M2FA 355 SA	3GFA 354 110-••A	740	93.4	0.75	318	5.3	1934	1.3	2.0	
185	¹⁾ M2FA 355 SB	3GFA 354 120-••A	740	93.9	0.76	381	5.6	2385	1.4	2.0	
750 r/min = 8 poles			400 V 50 Hz			High-output design					
90	¹⁾ M2FA 280 MB	3GFA 284 320-••A	739	92.6	0.75	192	6.7	1162	1.6	2.2	

The two bullets in the product code indicate choice of mounting arrangement, voltage and frequency (see ordering information page).

¹⁾ Temperature rise class F.

²⁾ On request.

General purpose open drip proof motors

Technical data for squirrel cage

three phase motors, steel frame

IP 23 S – IC 01 – Insulation class F, temperature rise class B

Output kW	Motor type	Speed r/min	Efficiency %	Power factor cos φ	Current I _N A	Speed r/min	Efficiency %	Power factor cos φ	Current I _N A	Moment of inertia J = ¼ GD ² kgm ²	Weight kg	Sound pressure level L _p dB(A)
1000 r/min = 6 poles		380 V 50 Hz				415 V 50 Hz				Basic design		
75	M2FA 280 SA	985	92.7	0.79	158	986	92.7	0.79	146	1.65	440	²⁾
90	¹⁾ M2FA 280 SMA	986	92.9	0.79	190	987	93.1	0.78	178	2.6	475	²⁾
110	M2FA 315 SA	986	93.4	0.85	212	989	93.5	0.78	209	2.9	630	²⁾
132	M2FA 315 SMA	986	93.7	0.85	256	989	94.0	0.81	242	3.8	720	²⁾
160	M2FA 315 MB	986	94.0	0.85	310	989	94.1	0.8	300	4.5	810	²⁾
185	¹⁾ M2FA 315 LA	986	94.2	0.85	352	988	94.4	0.79	340	5.4	915	²⁾
200	M2FA 355 SA	989	94.5	0.84	385	990	94.7	0.81	364	8.7	1220	²⁾
250	M2FA 355 SB	989	94.7	0.84	478	991	94.8	0.81	446	10.2	1320	²⁾
300	M2FA 355 MA	988	94.9	0.85	546	991	95.1	0.82	528	12.5	1550	²⁾
1000 r/min = 6 poles		380 V 50 Hz				415 V 50 Hz				High-output design		
110	¹⁾ M2FA 280 MB	986	93.4	0.79	231	988	93.6	0.77	219	2.9	545	²⁾
750 r/min = 8 poles		380 V 50 Hz				415 V 50 Hz				Basic design		
55	M2FA 280 SA	736	89.9	0.81	119	739	91.2	0.77	114	1.85	460	²⁾
75	¹⁾ M2FA 280 SMA	736	91.7	0.79	161	739	91.8	0.75	157	2.2	500	²⁾
90	M2FA 315 SMA	738	92.7	0.80	186	740	92.9	0.76	179	3.8	720	²⁾
110	M2FA 315 MB	738	93.2	0.80	233	740	93.4	0.76	219	4.5	810	²⁾
132	¹⁾ M2FA 315 LA	737	93.1	0.80	275	740	93.3	0.76	262	5.4	915	²⁾
150	M2FA 355 SA	739	93.3	0.77	322	741	93.4	0.73	311	8.7	1220	²⁾
185	¹⁾ M2FA 355 SB	739	93.7	0.78	393	741	93.9	0.74	372	10.2	1320	²⁾
750 r/min = 8 poles		380 V 50 Hz				415 V 50 Hz				High-output design		
90	¹⁾ M2FA 280 MB	738	92.5	0.78	192	740	92.6	0.74	188	2.9	575	²⁾

The two bullets in the product code indicate choice of mounting arrangement, voltage and frequency (see ordering information page).

¹⁾ Temperature rise class F.

²⁾ On request.

General purpose open drip proof motors

Technical data for squirrel cage

three phase motors, steel frame, two speed

IP 23 S – IC 01 – Insulation class F, temperature rise class F

Output kW	Motor type	Product code	Speed r/min	Efficiency %	Power factor cos φ	Current		Torque			Moment of inertia J = 1/4 GD ² kgm ²	Weight kg	
						I _N A	I _s I _N	T _N Nm	T _s T _N	T _{max} T _N			
1500/1000 r/min = 4/6-poles												Fan drive. two separate windings	
90/30	M2FA 280 SMA	3GFA 288 214-••A	1480/987	91.0/86.3	0.85/0.76	168/65	6.7/7.2	581/290	1.7/2.6	2.7/2.4	1.4	490	
110/32	M2FA 280 MB	3GFA 288 324-••A	1482/988	92.3/87.4	0.84/0.77	204/69	7.4/7.3	709/309	2.1/2.7	2.8/2.7	1.7	550	
132/40	M2FA 315 SMA	3GFA 318 214-••A	1484/989	92.6/89.2	0.85/0.79	239/84	6.3/6.4	849/386	1.5/2.1	2.4/2.4	2.3	735	
170/50	M2FA 315 MB	3GFA 318 324-••A	1486/988	93.4/89.7	0.83/0.78	310/103	7.3/6.3	1092/483	1.8/2.3	2.8/2.3	2.9	850	
200/63	M2FA 315 LA	3GFA 318 514-••A	1486/989	93.9/90.8	0.83/0.76	362/130	7.7/7.4	1285/608	2.0/2.8	2.9/2.7	3.5	970	
260/85	M2FA 355 SA	3GFA 358 114-••A	1487/990	94.5/91.8	0.83/0.78	473/171	6.3/7.0	1670/820	1.4/2.3	2.4/2.4	5.5	1220	
340/100	M2FA 355 MA	3GFA 358 314-••A	1488/989	95.0/92.0	0.82/0.79	620/199	7.0/6.5	2182/966	1.5/2.1	2.7/2.3	6.5	1320	
400/120	M2FA 355 LA	3GFA 358 514-••A	1487/992	94.9/92.1	0.88/0.78	680/240	7.0/8.8	2569/1155	1.3/2.3	2.4/3.0	7.8	1550	
1500/750 r/min = 4-8 poles												Fan drive. Dahlander-Connection	
100/25	M2FA 280 SMA	3GFA 288 219-••A	1478/735	92.0/87.6	0.85/0.68	185/62	6.2/4.1	646/325	1.5/1.5	2.4/1.7	1.4	490	
110/28	M2FA 280 MB	3GFA 288 329-••A	1479/735	92.4/88.3	0.86/0.68	199/67	6.7/4.1	710/364	1.7/1.5	2.4/1.7	1.7	550	
140/35	M2FA 315 SMA	3GFA 318 219-••A	1485/740	93.5/89.9	0.83/0.64	259/87	6.8/4.7	900/452	1.5/1.6	2.6/1.9	2.3	735	
185/46	M2FA 315 MB	3GFA 318 329-••A	1483/738	93.7/90.5	0.85/0.67	333/110	6.5/4.2	1191/595	1.5/1.4	2.4/1.7	2.9	850	
220/55	M2FA 315 LA	3GFA 318 519-••A	1485/739	94.2/91.2	0.83/0.64	397/136	7.6/4.6	1415/711	1.7/1.5	2.8/2.0	3.5	975	
250/63	M2FA 355 MA	3GFA 358 319-••A	1486/740	94.7/92.2	0.86/0.66	440/148	6.3/4.0	1607/813	1.1/1.0	2.3/1.7	6.5	1320	
315/80	M2FA 355 LA	3GFA 358 519-••A	1489/741	95.1/93.0	0.84/0.64	560/195	8.0/5.0	2020/1031	1.7/1.4	2.9/2.0	7.8	1550	
1500/1000 r/min = 4/6 poles												Constant torque, two separate windings	
75/50	M2FA 280 SMA	3GFA 289 214-••A	1480/984	89.6/87.9	0.86/0.77	140/105	6.2/6.3	484/485	1.5/2.4	2.3/2.4	1.4	490	
90/60	M2FA 280 MB	3GFA 289 324-••A	1481/987	91.0/89.3	0.86/0.73	169/131	6.8/6.9	580/581	1.7/2.7	2.5/2.6	1.7	550	
120/80	M2FA 315 SMA	3GFA 319 214-••A	1486/988	91.8/91.2	0.85/0.75	225/171	6.3/6.2	771/773	1.5/2.3	2.5/2.3	2.3	735	
150/100	M2FA 315 MB	3GFA 319 324-••A	1488/989	92.6/91.8	0.82/0.75	285/215	7.6/6.6	986/966	1.8/2.5	2.9/2.5	2.9	850	
185/125	M2FA 315 LA	3GFA 319 514-••A	1486/988	93.4/92.2	0.83/0.73	345/265	7.8/6.8	1189/1208	1.9/2.8	2.9/2.5	3.5	970	
200/130	M2FA 355 SA	3GFA 359 114-••A	1487/991	93.5/92.9	0.88/0.83	360/248	7.8/9.0	1284/1253	1.2/2.3	3.0/3.2	8.5	1220	
240/160	M2FA 355 MA	3GFA 359 314-••A	1489/991	94.1/93.4	0.84/0.84	439/289	8.6/8.8	1539/1542	1.6/2.4	3.4/2.8	10.2	1320	
1500/750 r/min = 4-8 poles												Constant torque, Dahlander-Connection	
85/48	M2FA 280 SMA	3GFA 289 219-••A	1480/740	91.2/89.9	0.84/0.65	159/119	5.5/5.4	548/619	1.5/2.7	2.2/2.3	2.6	475	
100/55	M2FA 280 MB	3GFA 289 329-••A	1479/740	91.2/90.6	0.87/0.70	183/125	5.4/5.5	646/710	1.6/2.5	2.1/2.2	2.9	545	
125/80	M2FA 315 SMA	3GFA 319 219-••A	1481/739	92.0/91.6	0.88/0.75	220/164	6.0/5.8	806/1034	1.3/1.8	2.1/2.0	4.1	755	
150/95	M2FA 315 MB	3GFA 319 329-••A	1481/739	92.4/91.9	0.88/0.75	262/194	6.1/5.7	967/1228	1.4/1.8	2.1/2.0	4.9	845	
185/120	M2FA 315 LA	3GFA 319 519-••A	1482/739	92.8/92.2	0.88/0.75	325/247	6.5/5.9	1192/1551	1.5/1.9	2.2/2.0	5.8	950	
225/125	M2FA 355 MA	3GFA 359 319-••A	1486/743	93.6/91.8	0.91/0.73	386/271	6.7/6.2	1446/1607	1.1/1.6	2.4/2.5	10.2	1320	
300/160	M2FA 355 LA	3GFA 359 519-••A	1489/744	94.0/92.5	0.88/0.68	512/368	8.1/7.1	1924/2054	1.5/2.0	2.8/2.9	12.5	1550	

The two bullets in the product code indicate choice of mounting arrangement, voltage and frequency (see ordering information page).

Data for other number of poles and bigger frame sizes on request.

General purpose open drip proof motors - Variant codes

Code ¹⁾	Variant	Motor size			
		280	315	355	400
Balancing					
052	Vibration acc. to grade A (IEC 60034-14).	S	S	S	S
417	Vibration acc. to grade B (IEC 60034-14).	P	P	P	P
424	Full key balancing.	P	P	P	P
Bearings and lubrication					
036	Transport lock for bearings.	P	P	P	P
037	Roller bearing at D-end.	P	P	P	P
043	SPM nipples.	P	P	P	P
058	Angular contact bearing at D-end, shaft force away from bearing.	P	P	P	P
107	Pt100 2-wire in bearings.	P	P	P	P
420	Bearing mounted PTC-thermistors.	P	P	P	P
Branch standard designs					
209	Non-standard voltage or frequency (special winding).	P	P	P	P
Coupling					
035	Assembly of customer supplied coupling-half.	P	P	P	P
Heating elements					
450	Heating element, 100-120 V.	P	P	P	P
451	Heating element, 200-240 V.	P	P	P	P
Insulation system					
014	Winding insulation class H.	R	R	R	R
Mounting arrangements					
009	IM 2001 foot/flange mounted, from IM 1001 (B35 from B3).	P	P	P	P
066	Modified for non-standard mounting position (please specify IM xxxx). (must be ordered for all mounting arrangements excluding IM B3 (1001) and B5 (3001)).	P	P	P	P
Painting					
114	Special paint colour, standard grade.	P	P	P	P
Protection					
005	Protective roof, vertical motor, shaft down.	P	P	P	P
072	Radial seal at D-end.	P	P	P	P
Rating & instruction plates					
002	Restamping voltage, frequency and output, continuous duty.	P	P	P	P
095	Restamping output (maintained voltage, frequency), intermittent duty.	P	P	P	P
135	Mounting of additional identification plate, stainless.	P	P	P	P
161	Additional rating plate delivered loose.	P	P	P	P

¹⁾ Certain variant codes cannot be used together.

M = On modification of a stocked motor, or on new manufacture, the number per order may be limited.

R = On request

S = Included as standard

P = New manufacture only

Code ¹⁾	Variant	Motor size			
		280	315	355	400
Shaft & rotor					
069	Two shaft extensions as per basic catalogue.	P	P	P	P
070	One or two special shaft extensions, standard shaft material.	P	P	P	P
Stator winding temperature sensors					
121	Bimetal detectors, break type (NCC), (3 in series), 130°C, in stator winding.	P	P	P	P
122	Bimetal detectors, break type (NCC), (3 in series), 150°C, in stator winding.	P	P	P	P
123	Bimetal detectors, break type (NCC), (3 in series), 170°C, in stator winding.	P	P	P	P
125	Bimetal detectors, break type (NCC), (2x3 in series), 150°C, in stator winding.	P	P	P	P
127	Bimetal detectors, break type (NCC), (3 in series, 130°C & 3 in series, 150°C), in stator winding.	P	P	P	P
435	PTC-thermistors (3 in series), 130°C, in stator winding.	P	P	P	P
436	PTC-thermistors (3 in series), 150°C, in stator winding.	S	S	S	S
437	PTC-thermistors (3 in series), 170°C, in stator winding.	P	P	P	P
439	PTC-thermistors (2x3 in series), 150°C, in stator winding.	P	P	P	P
441	PTC-thermistors (3 in series, 130°C & 3 in series, 150°C), in stator winding.	P	P	P	P
442	PTC-thermistors (3 in series 150°C & 3 in series 170°C), in stator winding.	P	P	P	P
445	Pt100 2-wire in stator winding, 1 per phase.	P	P	P	P
446	Pt100 2-wire in stator winding, 2 per phase.	P	P	P	P
Terminal box					
021	Terminal box LHS, seen from D-end (= L prod.code).	P	P	P	P
180	Terminal box RHS, seen from (reconnection from D).	P	P	P	P
022	Cable entry LHS (seen from D-end).	P	P	P	P
468	Cable entry from D-end.	P	P	P	P
Testing					
145	Type test report from a catalogue motor, 400 V 50 Hz.	P	P	P	P
146	Type test with report for motor from specific delivery batch.	P	P	P	P
147	Type test with report for motor from specific delivery batch, customer witnessed.	P	P	P	P
148	Routine test report.	P	P	P	P
149	Testing according to separate test specification.	R	R	R	R
222	Torque/speed curve, type test and multi-point load test with report for motor from specific delivery batch.	P	P	P	P
153	Reduced test for classification society.	P	P	P	P
760	Vibration level test.	P	P	P	P
761	Vibration spectrum test.	P	P	P	P
762	Noise level test.	P	P	P	P
763	Noise spectrum test.	P	P	P	P

¹⁾ Certain variant codes cannot be used together.

M = On modification of a stocked motor, or on new manufacture, the number per order may be limited.

R = On request

S = Included as standard

P = New manufacture only

General purpose open drip proof motors

Sizes 280 - 315

Dimension drawings

Foot-mounted; IM B3 (IM 1001), IM B6 (IM 1051), IM B8 (IM 1071), IM V5 (IM 1011)

Terminal box top-mounted

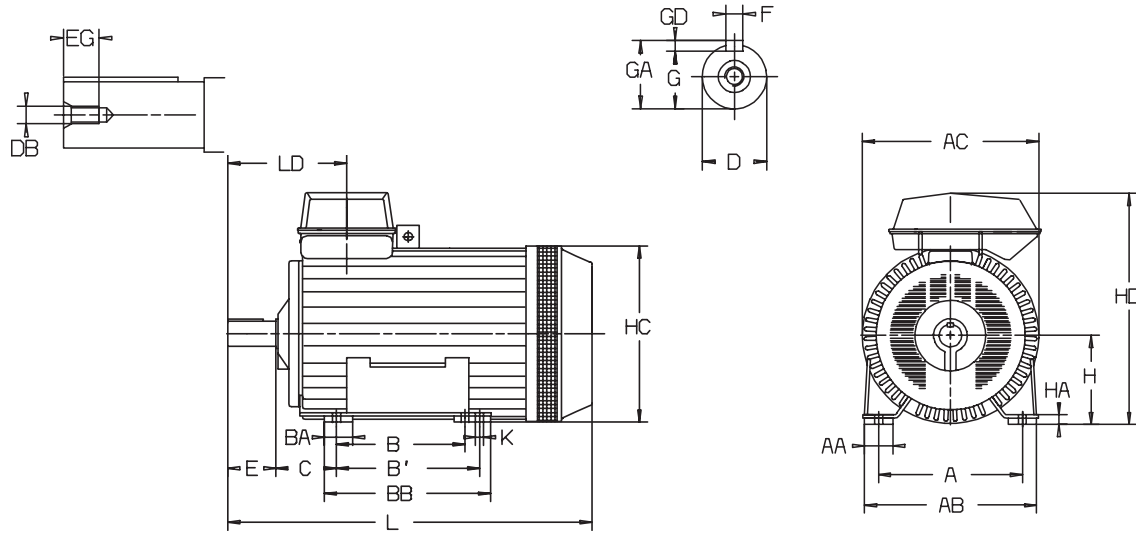

Motor size	Poles	A	AA	AB	AC	B	B'	BA	BB	C	D	DB	E	EG
280 SA	4-8	457	80	545	555	368	-	100	450	190	80	M20	170	40
280 SMA	2	457	80	545	555	368	419	100	501	190	65	M20	140	40
280 SMA	4-8	457	80	545	555	368	419	100	501	190	80	M20	170	40
280 MB	2	457	80	545	555	419	-	100	501	190	65	M20	140	40
280 MB	4-8	457	80	545	555	419	-	100	501	190	80	M20	170	40
315 SA	2	508	100	622	624	406	-	100	535	216	70	M20	140	40
315 SA	4-6	508	100	622	624	406	-	100	535	216	90	M24	170	48
315 SMA	2	508	100	622	624	406	457	100	540	216	70	M20	140	40
315 SMA	4-8	508	100	622	624	406	457	100	540	216	90	M24	170	48
315 MB, MC	2	508	100	622	624	457	-	100	540	216	70	M20	140	40
315 MB	4-8	508	100	622	624	457	-	100	540	216	90	M24	170	48
315 LA, LB	2	508	100	622	624	508	-	100	592	216	70	M20	140	40
315 LA, LB	4-8	508	100	622	624	508	-	100	592	216	90	M24	170	48

Motor size	Poles	F	G	GA	GD	H	HA	HC	HD	K	L	LD
280 SA	4-8	22	71	85	14	280	32	556	730	24	1020	415
280 SMA	2	18	58	69	11	280	32	556	730	24	1060	385
280 SMA	4-8	22	71	85	14	280	32	556	730	24	1090	415
280 MB	2	18	58	69	11	280	32	556	730	24	1120	385
280 MB	4-8	22	71	85	14	280	32	556	730	24	1150	415
315 SA	2	20	62.5	74.5	12	315	32	625	820	28	1123	392
315 SA	4-6	25	81	95	14	315	32	625	820	28	1153	422
315 SMA	2	20	62.5	74.5	12	315	32	625	820	28	1223	392
315 SMA	4-8	25	81	95	14	315	32	625	820	28	1153	422
315 MB, MC	2	20	62.5	74.5	12	315	32	625	820	28	1223	392
315 MB	4-8	25	81	95	14	315	32	625	820	28	1253	422
315 LA, LB	2	20	62.5	74.5	12	315	32	625	820	28	1293	392
315 LA, LB	4-8	25	81	95	14	315	32	625	848	28	1323	422

Tolerances:

A,B	ISO js 14	H	0, -0.5 (M2FA 250)
D	ISO m6		0, -1.0 (M2FA 280-315)
F	ISO h9		

Above table gives the main dimensions in mm.
For detailed drawings please see our web-site
www.abb.com/motors&drives or contact us.

General purpose open drip proof motors

Sizes 280 - 315

Dimension drawings

Flange-mounted; IM B5 (IM 3001), IM V1 (IM 3011)

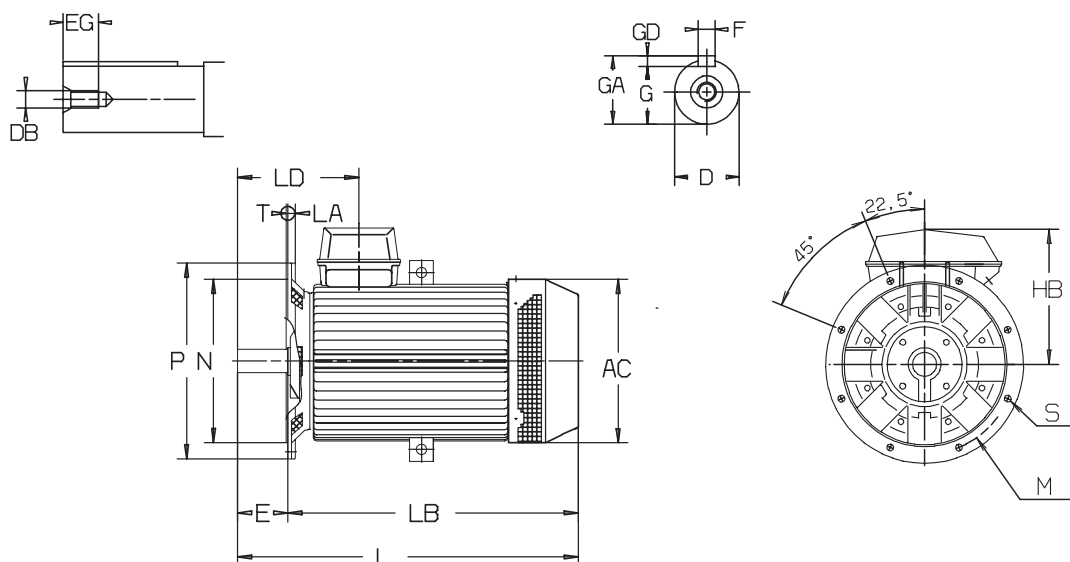

M000106

Motor size	Poles	AC	D	DB	E	EG	F	G	GA	GD	HB
280 SA	4-8	551	80	M20	170	40	22	71	85	14	450
280 SMA	2	551	65	M20	140	40	18	58	69	11	450
280 SMA	4-8	551	80	M20	170	40	22	71	85	14	450
280 MB	2	551	80	M20	140	40	18	58	69	11	450
280 MB	4-8	551	80	M20	170	40	22	71	85	14	450
315 SA	2	620	70	M20	140	40	20	62.5	74.5	12	505
315 SA	4-6	620	90	M24	170	48	25	81	95	14	505
315 SMA	2	620	70	M20	140	40	20	62.5	74.5	12	505
315 SMA	4-8	620	90	M24	170	48	25	81	95	14	505
315 MB, MC	2	620	70	M20	140	40	20	62.5	74.5	12	505
315 MB	4-8	620	90	M24	170	48	25	81	95	14	505
315 LA	2	620	70	M20	140	40	20	62.5	74.5	12	505
315 LA	4-8	620	90	M24	170	48	25	81	95	14	505
315 LB	2	620	70	M20	140	10	20	62.5	74.5	12	533

Motor size	Poles	L	LA	LB	LD	M	N	P	S	T
280 SA	4-8	1020	25	850	410	600	550	660	23	6
280 SMA	2	1060	25	920	380	600	550	660	23	6
280 SMA	4-8	1090	25	920	410	600	550	660	23	6
280 MB	2	1120	25	980	380	600	550	660	23	6
280 MB	4-8	1150	25	980	410	600	550	660	23	6
315 SA	2	1123	25	983	390	740	680	800	23	6
315 SA	4-6	1153	25	983	420	740	680	800	23	6
315 SMA	2	1223	25	1083	390	740	680	800	23	6
315 SMA	4-8	1153	25	983	420	740	680	800	23	6
315 MB, MC	2	1223	25	1083	390	740	680	800	23	6
315 MB	4-8	1253	25	1083	420	740	680	800	23	6
315 LA	2	1293	25	1153	390	740	680	800	23	6
315 LA	4-8	1323	25	1153	420	740	680	800	23	6
315 LB	2	1293	25	1153	390	740	680	800	23	6

Tolerances:

D ISO m6
F ISO h9
N ISO js6

Above table gives the main dimensions in mm.
For detailed drawings please see our web-site
www.abb.com/motors&drives or contact us.

Dimension drawings

Foot-mounted; IM B3 (IM 1001), IM B6 (IM 1051), IM B8 (IM 1071), IM V5 (IM 1011)
Terminal box top-mounted

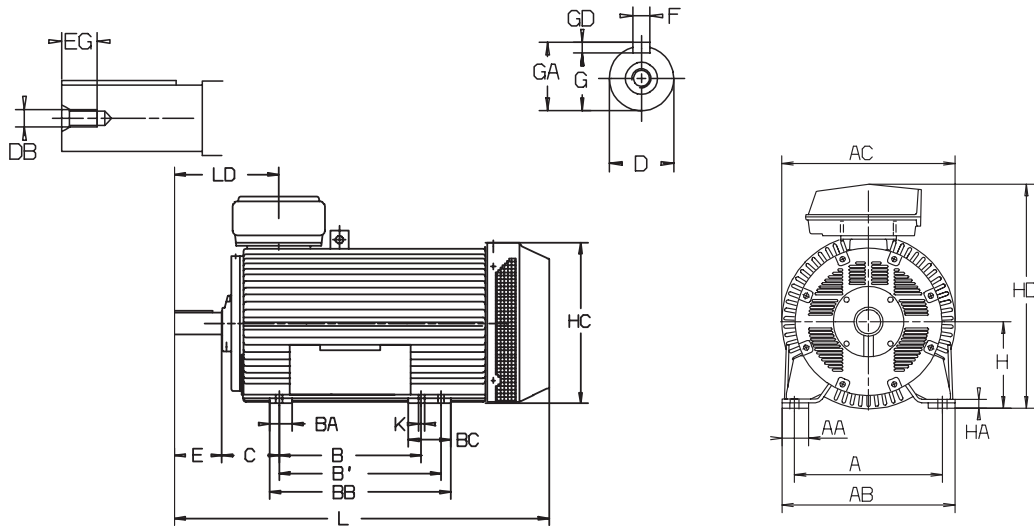

M000105

Motor size	Poles	A	AA	AB	AC	B	B'	BA	BB	BC	C	D	DB	E	EG
355 S_	2	610	110	714	716	500	-	100	584	-	254	75	M20	140	40
355 SA	4-8	610	110	714	716	500	-	100	584	-	254	100	M24	210	48
355 SB,SC	4	610	110	714	716	500	-	100	584	-	254	100	M24	210	48
355 SB,SC	6-8	610	110	714	716	500	-	100	584	-	254	100	M24	210	48
355 M_	2	610	110	714	716	560	-	100	644	-	254	75	M20	140	40
355 M_	4	610	110	714	716	560	-	100	644	-	254	100	M24	210	48
355 M_	6-8	610	110	714	716	560	-	100	644	-	254	100	M24	210	48
355 L_	2	610	110	714	716	630	-	100	714	-	254	75	M20	140	40
355 L_	4	610	110	714	716	630	-	100	714	-	254	100	M24	210	48
355 L_	6-8	610	110	714	716	630	-	100	714	-	254	100	M24	210	48
355 LK_	2	610	110	714	716	630	710	100	802	180	254	75	M20	140	40
355 LK_	4-8	610	110	714	716	630	710	100	802	180	254	100	M24	210	48
400 LK_	2	686	140	820	810	710	800	140	935	220	280	90	M24	170	48
400 LK_	4-8	686	140	820	810	710	800	140	935	220	280	100	M24	210	48

Motor size	Poles	F	G	GA	GD	H	HA	HC	HD	K	L	LD
355 S_	2	20	67.5	79.5	12	355	36	713	920	28	1310	397
355 SA	4-8	28	90	106	16	355	36	713	892	28	1380	467
355 SB,SC	4	28	90	106	16	355	36	713	920	28	1380	467
355 SB,SC	6-8	28	90	106	16	355	36	713	892	28	1380	467
355 M_	2	20	67.5	79.5	12	355	36	713	920	28	1370	397
355 M_	4	28	90	106	16	355	36	713	920	28	1440	467
355 M_	6-8	28	90	106	16	355	36	713	892	28	1440	467
355 L_	2	20	67.5	79.5	12	355	36	713	920	28	1450	397
355 L_	4	28	90	106	16	355	36	713	920	28	1520	467
355 L_	6-8	28	90	106	16	355	36	713	892	28	1520	467
355 LK_	2	20	67.5	79.5	12	355	36	713	920	28	1590	397
355 LK_	4-8	28	90	106	16	355	36	713	920	28	1660	467
400 LK_	2	25	81	95	14	400	45	805	1003	35	1786	438
400 LK_	4-8	28	90	106	16	400	45	805	1003	35	1826	478

Tolerances:

- A,B ISO js 14
- D ISO m6
- F ISO h9
- H 0, -1.0

Above table gives the main dimensions in mm.

For detailed drawings please see our web-site www.abb.com/motors&drives or contact us.

General purpose open drip proof motors

Sizes 355 - 400

Dimension drawings

Flange-mounted; IM B5 (IM 3001), IM V1 (IM 3011)

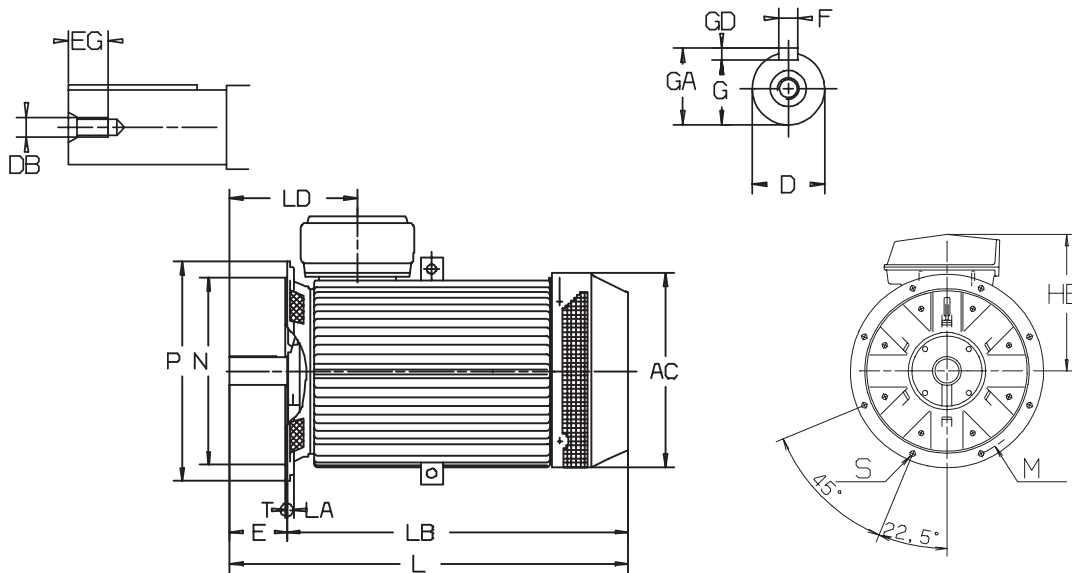

M000107

Motor size	Poles	AC	D	DB	E	EG	F	G	GA	GD	HB
355 S_	2	716	75	M20	140	40	20	67.5	79.5	12	565
355 SA	4-8	716	100	M24	210	48	28	90	106	16	537
355 SB,SC	4	716	100	M24	210	48	28	90	106	16	565
355 SB,SC	6-8	716	100	M24	210	48	28	90	106	16	537
355 M_	2	716	75	M20	140	40	20	67.5	79.5	12	565
355 M_	4	716	100	M24	210	48	28	90	106	16	565
355 M_	6-8	716	100	M24	210	48	28	90	106	16	537
355 L_	2	716	75	M20	140	40	20	67.5	79.5	12	565
355 L_	4	716	100	M24	210	48	28	90	106	16	565
355 L_	6-8	716	100	M24	210	48	28	90	106	16	537
355 LK_	2	716	75	M20	140	40	20	67.5	79.5	12	565
355 LK_	4-8	716	100	M24	210	48	28	90	106	16	565
400 LK_	2	810	90	M24	170	48	25	81	95	14	565
400 LK_	4-8	810	100	M24	210	48	28	90	106	16	565

Motor size	Poles	L	LA	LB	LD	M	N	P	S	T
355 S_	2	1310	25	1170	395	740	680	800	23	6
355 SA	4-8	1380	25	1170	465	740	680	800	23	6
355 SB,SC	4	1380	25	1170	465	740	680	800	23	6
355 SB,SC	6-8	1380	25	1170	465	740	680	800	23	6
355 M_	2	1370	25	1230	395	740	680	800	23	6
355 M_	4	1440	25	1230	465	740	680	800	23	6
355 M_	6-8	1440	25	1230	465	740	680	800	23	6
355 L_	2	1450	25	1310	395	740	680	800	23	6
355 L_	4	1520	25	1310	465	740	680	800	23	6
355 L_	6-8	1520	25	1310	465	740	680	800	23	6
355 LK_	2	1590	25	1450	395	740	680	800	23	6
355 LK_	4-8	1660	25	1450	465	740	680	800	23	6
400 LK_	2	1786	28	1616	438	940	880	1000	28	6
400 LK_	4-8	1826	28	1616	478	940	880	1000	28	6

Tolerances:

D ISO m6
F ISO h9
N ISO js6

Above table gives the main dimensions in mm.

For detailed drawings please see our web-site www.abb.com/motors&drives or contact us.

General purpose open drip proof motors

Dimension drawings

Terminal box in standard design
with 6 terminals

Top-mounted terminal box:

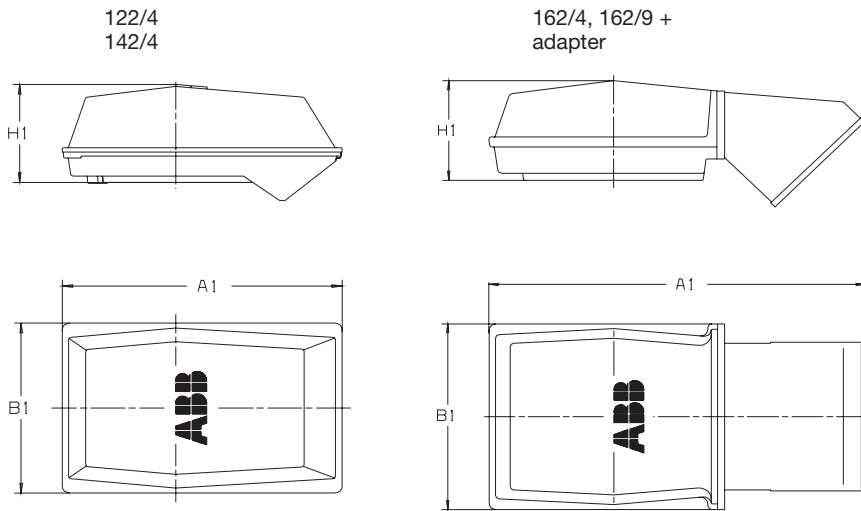

Side-mounted terminal box:

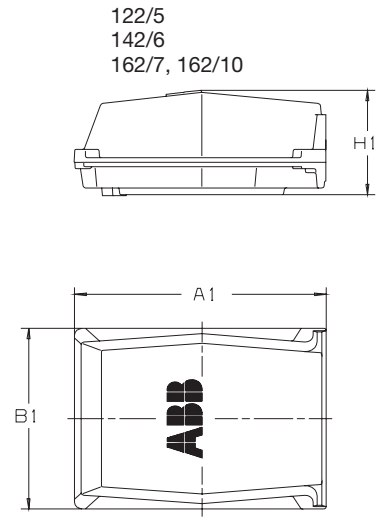

M000080

Terminal box type	Motor size	A1	B1	H1
-------------------	------------	----	----	----

Top-mounted terminal box:

122/4	280	455	280	177
142/4	315 - 355	536	349	197
162/4, 162/9 + Adapter	315 - 400	787	410	226

Side-mounted terminal box:

122/5	280	383	280	180
142/6	315 - 355	426	347	201
162/7, 162/10	315 - 400	508	412	226

Further details on terminal boxes on earlier pages.
For motor dimensions please see dimension drawings on earlier pages.

5

Rating plate

The rating plate is in table form giving values for speed, current and power factor for six voltages.

ABB Oy, Motors Vaasa, Finland						
3~ Motor M2FA 315 MB 4 B3						
IEC 315 S/M 80						
S1				No. 0320-010119452		
				Ins.cl. F		IP 23 S
V	Hz	kW	r/min	▲	cosφ	Duty
690 Y	50	250	1481	261	0,83	S1
400 D	50	250	1481	452	0,83	S1
660 Y	50	250	1479	271	0,86	S1
380 D	50	250	1479	470	0,86	S1
415 D	50	250	1482	441	0,83	S1
440 D	60	287	1779	460	0,86	S1
Prod. code 3GBA313220-ADD						
				Nmax		r/min
6319/C3		6316/C3				850 kg
				ABB		IEC 60034-1

M000109

General purpose open drip proof motors in brief, basic design

Motor frame size		280	315	355	400	
Stator	Material	Profile-pressed sheet steel				
	Paint colour shade	Blue, Munsell 8B 4.5/3.25 / NCS 4822-B05G / RAL 5014				
	Paint thickness	Two-pack epoxy paint, thickness $\geq 70 \mu\text{m}$				
Bearing end shields	Material	Cast iron GG 20/GRS 200				
	Paint colour shade	Blue, Munsell 8B 4.5/3.25 / NCS 4822-B05G / RAL 5014				
	Paint thickness	Two-pack epoxy paint, thickness $\geq 70 \mu\text{m}$				
Bearings	D-end	2-pole	6316/C4	6316/C4	on request	on request
		4-12 poles	6319/C3	6319/C4	6322/C3	6322/C3
	N-end	2-pole	6316/C4	6316/C4	on request	on request
		4-12 poles	6316/C3	6316/C3	6319/C3	6319/C3
Axially-locked bearings	Inner bearing cover	As standard, locked at D-end				
Bearing seal		V-ring as standard, radial seal on request				
Lubrication		Regreasing nipples, M10x1 Grease for bearing temperatures -30°C to $+120^{\circ}\text{C}$				
Rating plate		Stainless steel, with individual serial number				
SPM-nipples		On request				
Terminal box	Frame material	Cast iron GG 15 / GRS 150				
	Cover material	Cast iron GG 15 / GRS 150				
	Cover screw material	Steel 5G, coated with zinc and yellow chromated				
Connections	Cable	2 - 4 pole	2 x M63	2 x Ø50/80	2 x Ø80	
		6 pole	2 x M63	2 x Ø60	2 x Ø60/80	
	Terminals	6 terminals for connection with cable lugs (not included)				
Fan	Material	Siluminium				
Fan cover	Material	Sheet steel				
	Paint colour shade	Blue, Munsell 8B 4.5/3.25 / NCS 4822-B05G / RAL 5014				
	Paint thickness	Two-pack epoxy polyester paint, thickness $\geq 80 \mu\text{m}$				
Stator winding	Material	Copper				
	Insulation	Insulation class F; temperature rise class B unless otherwise stated.				
	Winding protection	PTC-thermistors 150°C , 3 in series, as standard				
Rotor winding	Material	Pressure die-cast aluminium				
Balancing method		Half key balancing as standard				
Key way		Closed key way				
Heating elements	On request	50 W	2x50 W	2x65 W	2x65 W	
Drain holes		As standard, open on delivery				
Enclosure		IP 23S				
Cooling method		IC 01				

ABB Motors' total product offer

ABB offers several comprehensive ranges of AC motors and generators. We manufacture synchronous motors for even the most demanding applications, and a full range of low and high voltage induction motors. Our in-depth knowledge of virtually every type of industrial processing ensures we always specify the best solution for your needs.



Low voltage motors and generators

General purpose motor for standard applications

- Aluminum motors
- Steel motors
- Cast iron motors
- Open drip proof motors
- Global motors
- Brake motors
- Single phase motors
- Servomotors

Process performance motors for more demanding applications

- Aluminum motors
- Cast iron motors (IEC and NEMA)
- Motors for high ambient temperatures
- Permanent magnet motors
- High speed motors
- Wind turbine generators
- Smoke venting motors
- Water cooled motors
- Motors for roller table drives

Motors for hazardous areas

- Flameproof motors
- Increased safety motors
- Non-sparking motors
- Dust ignition proof motors

Marine motors

- Aluminum motors
- Steel motors
- Cast iron motors
- Open drip proof motors

High voltage and synchronous motors and generators

- High voltage cast iron motors
- Induction modular motors
- Slip ring motors
- Motors for hazardous areas
- Synchronous motors and generators
- DC motors and generators



Motors & Drives

> Motors

>> Low Voltage Motors

>>> General purpose motors

- Aluminum motors
- Steel motors
- Cast iron motors
- Open drip proof motors
- Global motors
- Brake motors
- Single phase motors

>>> Process performance motors

>>> Motors for hazardous areas

>>> Marine motors

>>> Other applications

- NEMA motors
- Permanent magnet motors
- Smoke venting motors
- Roller table motors
- Water cooled motors
- Fan application motors
- Roller table motors

> Generators

Low Voltage Motors

Manufacturing sites (*) and some of the larger sales companies.

Australia

ABB Australia Pty Ltd
601 Blackburn Road
Notting Hill VIC 3168
Tel: +61 (0) 8544 0000
Fax: +61 (0) 8544 0001

Austria

ABB AG
Clemens Holzmeisterstrasse 4
AT-1810 Wien
Tel: +43 (0) 1 601 090
Fax: +43 (0) 1 601 09 8305

Belgium

Asea Brown Boveri S.A.-N.V.
Hoge Wei 27
BE-1930 Zaventem
Tel: +32 (0) 2 718 6311
Fax: +32 (0) 2 718 6657

Canada

ABB Inc., BA Electrical Machines
10300 Henri-Bourassa Blvd, West,
Saint-Laurent, Quebec
Canada H4S 1N6
Tel: +1 514 832-6583
Fax: +1 514 332-0609

China*

ABB Shanghai Motors Co., Ltd.
88 Tianning Road
Minhang(Economical and Techno-
logical Development Zone)
200245 Shanghai
Tel: +86 21 5472 3133
Fax: +86 21 5472 5025

Chile

Asea Brown Boveri S.A.
P.O.Box 581-3
Santiago
Tel: +56 (0) 2 5447 100
Fax: +56 (0) 2 5447 405

Denmark

ABB A/S
Automation Products
Emil Neckelmanns Vej 14
DK-5220 Odense SØ
Tel: +45 65 47 70 70
Fax: +45 65 47 77 13

Finland*

ABB Oy
Motors
P.O.Box 633
FI-65101 Vaasa
Tel: +358 (0) 10 22 11
Fax: +358 (0) 10 22 47372

France

ABB Entrelec
ZA La Boisse BP 90145
300 Rue des Prés-Seigneurs
FR-01124 Montluel Cedex
Tel: +33 4 37 40 40 00
Fax: +33 4 37 40 40 72

Germany

ABB Automation Products GmbH
Motors & Drives
Wallstaedter Strasse 59
DE-68526 Ladenburg
Tel: +49 (0) 6203 717 717
Fax: +49 (0) 6203 717 600

Hong Kong

ABB (Hong Kong) Ltd.
Tai Po Industrial Estate,
3 Dai Hei Street,
Tai Po, New Territories,
Hong Kong
Tel: +852 2929 3838
Fax: +852 2929 3505

India*

ABB Ltd.
32, Industrial Area, N.I.T
Faridabad 121 001
Tel: +91 (0) 129 502 3001
Fax: +91 (0) 129 502 3006

Indonesia

PT. ABB Sakti Industri
JL. Gajah Tunggal Km.1
Jatiuwung, Tangerang 15136
Banten, Indonesia
Tel: +62 21 590 9955
Fax: +62 21 590 0115 - 6

Ireland

Asea Brown Boveri Ltd
Components Division
Belgard Road
Tallaght, Dublin 24
Tel: +353 (0) 1 405 7300
Fax: +353 (0) 1 405 7327

Italy*

ABB SACE SpA
LV Motors
Via dell' Industria 18
IT-20010 Vittuone, Milano
Tel: +39 02 90341
Fax: +39 02 9034 7289

Japan

ABB K.K.
26-1 Cerulean Tower
Sakuragaoka-cho, Shibuya-ku
Tokyo 150-8512
Tel: +81 (0) 3 578 46251
Fax: +81 (0) 3 578 46260

Korea

ABB Korea Ltd.
7-9fl, Oksan Bldg., 157-33
Sungshung-dong, Kangnam-ku
Seoul
Tel: +82 2 528 2329
Fax: +82 2 528 2338

Malaysia

ABB Malaysia Sdn. Bhd.
Lot 608, Jalan SS 13/1K
47500 Subang Jaya, Selangor
Tel: +60 3 5628 4888
Fax: +60 3 5631 2926

Mexico

ABB México, S.A. de C.V.
Apartado Postal 111
CP 54000 Tlalnepantla
Edo. de México, México
Tel: +52 5 328 1400
Fax: +52 5 390 3720

The Netherlands

ABB B.V.
Dept. LV motors (APP2R)
P.O.Box 301
NL-3000 AH Rotterdam
Tel: +31 (0) 10 4078 879
Fax: +31 (0) 10 4078 345

Norway

ABB AS
P.O.Box 154 Vollebakk
NO-0520 Oslo
Tel: +47 22 872 000
Fax: +47 22 872 541

Russia

ABB Industrial & Building Systems
Ltd.
Business Centre "Krugozor"
Obruchevea 30/1, Building 2
Moscow 117861
Tel: +7 495 960 2200, 956 93 93
Fax: +7 495 960 2209, 230 63 46

Singapore

ABB Industry Pte Ltd
2 Ayer Rajah Crescent
Singapore 139935
Tel: +65 6776 5711
Fax: +65 6778 0222

Spain*

Asea Brown Boveri S.A.
Automation Products - Fábrica
Motores
P.O.Box 81
ES-08200 Sabadell
Tel: +34 93 728 8500
Fax: +34 93 728 8741

Sweden*

ABB Automation Technologies AB
LV Motors
SE-721 70 Västerås
Tel: +46 (0) 21 329 000
Fax: +46 (0) 21 329 140

Switzerland

ABB Schweiz AG
Normelec/CMC Components
Motors&Drives
Badenerstrasse 790
Postfach
CH-8048 Zürich
Tel: +41 (0) 58 586 0000
Fax: +41 (0) 58 586 0603

Taiwan

ABB Ltd.
6F, No. 126, Nanking East Road,
Section 41
Taipei, 105 Taiwan, R.O.C.
Tel: +886 (0) 2 2577 6090
Fax: +886 (0) 2 2577 9467

Thailand

ABB Limited (Thailand)
161/1 SG Tower,
Soi Mahadlekluang 3,
Rajdamri, Bangkok 10330
Tel: +66 2 665 1000
Fax: +66 2 665 1042

The United Kingdom

ABB Ltd
Drives, Motors and Machines
Daresbury Park
Daresbury, Warrington
Cheshire, WA4 4BT
Tel: +44 (0) 1925 741 111
Fax: +44 (0) 1925 741 212

USA

ABB Inc.
Low Voltage Motors
16250 W. Glendale Drive
New Berlin, WI 53151
Tel: +1 262 785 3200
Fax: +1 262 780 8888

Venezuela

Asea Brown Boveri S.A.
P.O.Box 6649
Carmelitas,
Caracas 1010A
Tel: +58 (0) 2 238 2422
Fax: +58 (0) 2 239 6383



<http://www.abb.com/motors&drives>
<http://online.abb.com/motors&drives>